



Single Desk

Assembly & User Instructions



Standing

just **15 min** per hour
provides great
health benefits



Contents

Single

Use/Liability	3
Parts List/Tools	4
Assembly	5-8
Trouble Shooting	8
Specifications	9

Assembly



Make sure no obstacles are in the desk's path.
Make sure the desktop is not touching any walls.
Make sure all cords are appropriate length to accommodate the change in height.



WARNING
Pinch Point
Keep hands and fingers clear.



Keep children away from electric height-adjustable desks, control units and handsets. There is a risk of injury and electric shock.



Keep all electrical components away from liquids.



Do not sit or stand on the desk frame.
Do not crawl or lie under the desk frame.



Do not place any objects taller than 20" underneath the desk.



Do not open any of the components - the Legs, Control Box, or Switch.
There is a danger of electric shock.



This product is designed with a duty cycle of 10%
(2 min. on, 18 min. off).



In the event of a power outage or if the power cord is unplugged, a manual reset may be necessary - see USE section.



Use / Liability

This height adjustable desk has electric motors and is designed for use in dry work areas only.

The desk height is adjustable so that it can be positioned at the most ergonomically suitable height.

Any other use is at users risk.

Under no circumstances does the manufacturer accept warranty claims or liability claims for damages caused from improper use or handling of the desk frame.

Please be informed that the anti collision software is designed for furniture protection, not human protection.



IMPORTANT: You must RESET the desk prior to use.



Parts List

Tools



4mm Allen Wrench (included)



Phillips Head Screwdriver
and/or Power Drill



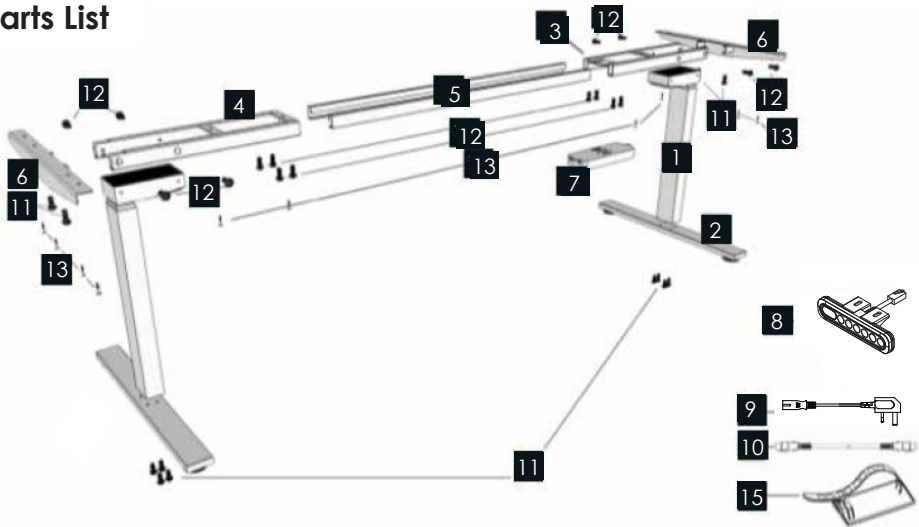

Tape Measure

Parts List



Part	Qty	Part	Qty	Part	Qty
1 Leg	2	6 Side Bracket	2	11 M6x14mm Machine Screw	23
2 Foot	2	7 Control Box	1	12 M6x10mm Machine Screw	16
3 Frame End-CB	1	8 Handset	1	13 M5x20mm Wood Screw	11
4 Frame End	1	9 Power Cord	1	14 M5x16mm Wood Screw	2
5 Centre Rail	2	10 Cable	1	15 Cable Chip	10

Assembly

Ensure there are no obstacles in the desk's path, and that the desktop is not touching any walls. Please also ensure that all cords are an appropriate length to accommodate the change in height.  

IMPORTANT: You must RESET the desk prior to use.

1

Lay out all components and hardware to ensure that you have all items listed on the parts page. Slide the Control Box (part 7) off the Frame End-CB (part 3) and set aside. Fully separate Frame End (part 4) from Frame End-CB (part 3). You will find the Centre Rail (part 5) inside.

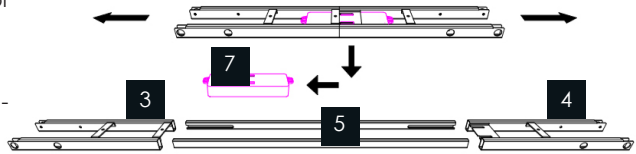

2

Place one of the Legs (part 1) into the Frame End-CB (part 3) ensuring that the bar (arrow) is on "top" in relation to the Leg (part 1).

Line up the holes on the Leg (part 1) with the holes on the Frame End-CB (part 3).

Using the supplied Allen Wrench, insert four (4) M6x10mm Machine Screws (part 12) through the holes in the Frame End-CB (part 3), going into the Leg (part 1) and rotate each screw just a few turns. After all four (4) M6x10mm Machine Screws (part 12) are inserted, tighten all four (4) screws.

Do the same for the other Leg (part 1) and the Frame End (part 4).

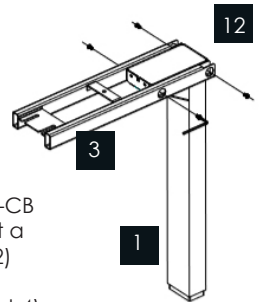

3

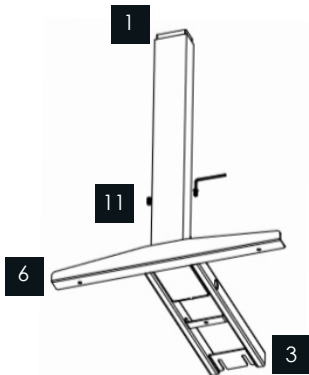

The Frame End-CB (part 3) should be placed on the side of the desk where you plan to mount the Control Box (part 7) and the Handset (part 8).

Slide the Side Bracket (part 6) into the Frame End-CB (part 3). Insert two (2) M6x14mm Machine Screws (part 11) through the two (2) holes in the bottom of the Frame End CB (part 3) going into the inserted Side Bracket (part 6). Using the supplied Allen Wrench, rotate each screw just a few turns. After both M6x-14mm Machine Screws are inserted, tighten both screws.

Do the same for the other frame end/leg assembly.

5

Assembly

- 4 Slide the two (2) Centre Rails (part 5) into the two Frame Ends (parts 3 & 4) ensuring: a) the slots in the Centre Rail (part 5) face inward b) the slots in the Centre Rail (part 5) are closer to the top edge when the assembly is upside down (see inset).

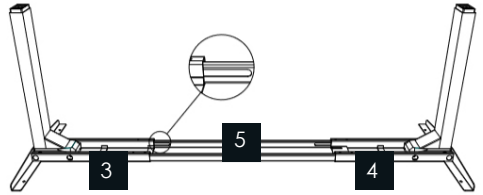

- 5 For each leg assembly, attach a Foot (part 2) with four (4) M6x14mm Machine Screws (part 11) and tighten in a cross-pattern.

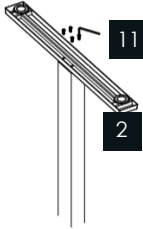

- 6 Check both sides of the desktop before placing the desk base on the underside of the desktop.

Adjust the width of the desk base to fit the desktop by sliding the two halves outward. We recommend leaving at least 1/2" of the desktop width (on each end) protruding beyond the frame width and centring the side brackets (part 6) before and after.

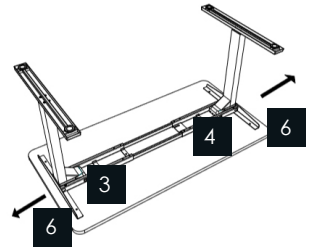

- 7
-

Lock the position of the Centre Rail (part 5) using eight (8) M6x10mm Machine Screws (part 12).



Ensure the M6x10mm Machine Screws (part 12) contacts the Centre Rail (part 5) by sliding the Centre Rail (part 5) as needed.

Assembly

8  Double check that the wood screws are not too long for your desktop and won't puncture the surface when screwed all the way in.

 We recommend that you pre-drill any holes needed for fasteners. Never use countersunk screws.

Double check that the desk base is properly positioned on the underside of the desktop.

If using different drilled top attach the desk base to the underside of the desktop using eleven (11) M5 x 20mm wood screws (part 13) Please note you will have eleven(11) M6 x 14mm machine screws (part 11) spare. OR

If using pre drilled top attach the desk base to the underside of the desktop using eleven(11) M6 x 14mm Machine screws (part 11). Please note you will have eleven (11) M5 x 20mm Wood screws (part 13) spare.

Attach the Handset (part 8) so the front of the handset is flush with the front desktop edge (or recessed up to 1/8"). The handset may be placed anywhere along the front edge of the desktop, but we recommend placing it towards an end so it prevents interference when seated. Use two (2) M5x16mm Wood Screws (part 14) to attach the handset to the desktop.



Do not overtighten screws in this step. Overtightening could cause damage to the components.

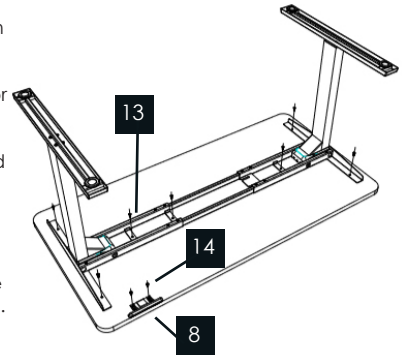

9 Slide the Control Box (part 7) onto the Frame End-CB (part 3).

Connect the cable exiting the Leg (Part 1) that is attached to the Frame End-CB (part 3) directly into the Control Box (part 7).

Connect the Cable (part 10) to the other Leg (part 1) and to the Control Box (part 7).

Connect the Handset (part 8) cable to the Control Box (part 7).

Connect the Power Cord (part 9) to the Control Box (part 7).

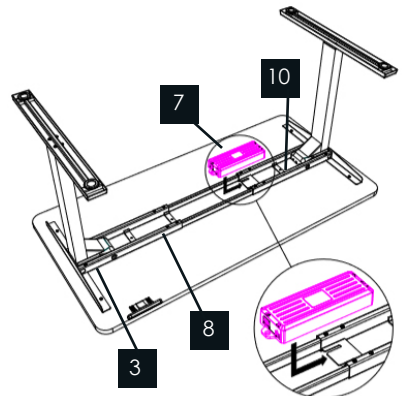

Use the adhesive-backed Cable Clips (part 15) to secure the cables so they do not sag. Please note you won't need extension cable (part 10) if using a small top. To keep cables neat and tidy we recommend you purchase a cable basket.

Assembly

10

With at least two people, grab the DESK BASE (not the desktop) and turn it right-side up. Adjust the pre the pre-install glides on the feet (part 2) as needed.

11

Plug the Power Cord (part 9) into a 230v outlet.

12

Ensure there are no obstacles in the desk's path, and that the desktop is not touching any walls. Please also ensure that all cords are an appropriate length to accommodate the change in height.



IMPORTANT: You must RESET the desk prior to use.

RESET PROCEDURE

Press and hold the DOWN button on the Handset (part 8) until the desk reaches its lowest height.

Release the DOWN button.

Press and hold the DOWN button again for about 10 seconds.

Release the DOWN button.

Press and hold the DOWN button again until the desk lowers a little bit more, slightly rises and stops.

Release the DOWN button.

Your desk is now ready to use.

The desk base can be adjusted by pressing and holding either the UP or DOWN button until the desired height is reached.

Specifications

Height Range	685 - 1185 mm (without desktop)
Base Width	1200 - 1800 mm
Travel Speed	40 mm per second (no load)
Distributed Load	125Kg
Duty Cycle	After 2 min. continuous use rest for 18 min to prevent overheating
	Soft start/stop
	Adjustable leveling studs



- Increase productivity
- Prolong life expectancy
- Improve circulation
- Burn fat

Standing just 15 min per hour provides great health benefits.



